

# INSTALLER MANUAL

## Pellet fireplace insert








©2020 CADEL srl | All rights reserved - Tutti i diritti riservati

# ZEFIRO<sup>3</sup> - ZEN AIRTIGHT

## SUMMARY

<b>1</b>	<b>MANUAL SIMBOLOGY</b> .....	<b>3</b>
<b>2</b>	<b>PACKAGING AND HANDLING</b> .....	<b>3</b>
2.1	PACKAGING .....	3
2.2	REMOVING THE STOVE FROM THE PALLET .....	3
2.3	STOVE HANDLING.....	4
<b>3</b>	<b>CHIMNEY FLUE</b> .....	<b>4</b>
3.1	INTRODUCTION .....	4
3.2	CHIMNEY FLUE.....	4
3.3	TECHNICAL FEATURES.....	5
3.4	HEIGHT-DEPRESSION.....	6
3.5	MAINTENANCE.....	6
3.6	CHIMNEY POT.....	6
3.7	CHIMNEY COMPONENTS .....	7
3.8	CHIMNEY FLUE CONNECTION.....	7
3.9	EXAMPLES OF CORRECT INSTALLATION.....	8
<b>4</b>	<b>COMBUSTION AIR</b> .....	<b>10</b>
4.1	EXTERNAL AIR INLET.....	10
4.2	COMBUSTIBLE AIR INLET FOR SEALED-CHAMBER INSTALLATION .....	11
4.3	COMBUSTIBLE AIR INLET FOR SEALED-CHAMBER INSTALLATION .....	11
<b>5</b>	<b>INSTALLATION</b> .....	<b>12</b>
5.1	INTRODUCTION .....	12
5.2	OVERALL DIMENSIONS .....	12
5.3	GENERAL INSTALLATION.....	13
5.4	INSERT EXTRACTION .....	14
5.5	INSERT REMOVAL.....	15
5.6	INSTALLATION WITH EXTERNAL COVER.....	16
5.7	INSTALLATION ON EXISTING FIREPLACE.....	17
5.8	DOOR ADJUSTMENT .....	18
5.9	ELECTRIC CONNECTION .....	19
5.10	CONNECTION TO THE EXTERNAL THERMOSTAT .....	19
5.11	AIR REGULATOR .....	20
5.12	INSERT LEGS INSTALLATION (OPTIONAL) .....	20
5.13	HOT AIR DUCTING (OPTIONAL) .....	21
5.14	PELLET DRAWER INSTALLATION (OPTIONAL).....	24
5.15	TRAPDOOR INSTALLATION (OPTIONAL).....	26
5.16	FRAME INSTALLATION (OPTIONAL) .....	27
5.17	CONCENTRIC PIPE INSTALLATION (OPTIONAL).....	28
5.18	DISPLAY ROTATION .....	28
<b>6</b>	<b>WI-FI KIT INSTALLATION</b> .....	<b>29</b>
<b>7</b>	<b>SPECIAL MAINTENANCE</b> .....	<b>30</b>
7.1	INTRODUCTION .....	30
7.2	FEED SCREW MAINTENANCE.....	31
7.3	FLUE GAS EXTRACTOR CLEANING.....	31
7.4	FUME PIPES ANNUAL CLEANING .....	32
7.5	GASKET REPLACEMENT.....	33
7.6	GLASS REPLACEMENT .....	33
<b>8</b>	<b>IN CASE OF ANOMALY</b> .....	<b>33</b>
8.1	PROBLEM SOLVING .....	33
<b>9</b>	<b>TECHNICAL DATAS</b> .....	<b>36</b>
9.1	FUSE REPLACEMENT .....	36
9.2	FEATURES.....	37

## 1 MANUAL SIMBOLOGY

	<b>USER</b>
	<b>AUTHORISED TECHNICIAN</b> <b>(ONLY to interpret or the Stove-manufacturer or the Authorized Technician of Technical Assistance Service approved by the Stove-manufacturer)</b>
	<b>SPECIALIZED STOVE-REPAIRER</b>
	<b>CAUTION:</b> <b>READ CAREFULLY THE NOTE</b>
	<b>CAUTION:</b> <b>DANGER OR IRREVERSIBLE DAMAGE POSSIBILITY</b>

- The icons with the stylized figures indicates whom the subject dealt in the paragraph is addressed to (between the User and/or the Authorized Technician and/or the Specialized Stove-repairer).
- WARNING symbols indicates an important note.

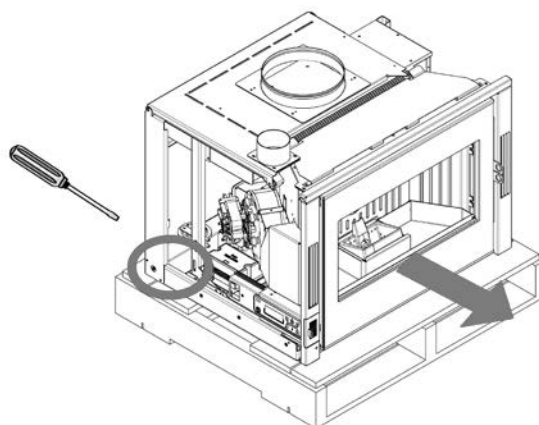
## 2 PACKAGING AND HANDLING

### 2.1 PACKAGING

- The packaging is made up of recyclable cardboard boxes according to RESY standards, recyclable expanded polystyrene inserts and wooden pallets.
- All packaging materials can be re-used for a similar use or eventually discharged as waste assimilable to the municipal solid ones, in accordance with current regulations.
- After having removed the packaging please assure you about the integrity of the product.

### 2.2 REMOVING THE STOVE FROM THE PALLET

Proceed as follows to remove the stove from the pallet:



*Fig. 1 - Screw removal*

- Slightly pull out the machine body from the structure (see **INSERT EXTRACTION a pag. 14**)
- Remove the screws fixed to the base of the insert (see **Fig. 1**) and then remove it from the pallet.

### 2.3 STOVE HANDLING

Both whether the stove is packed or not it is necessary to observe the following instructions for handling and transporting the stove from its sale point to its installation point and for any future movements:

- The stove must be handled with idoneous means paying attention to the existing safety regulations;
- do not turn the stove upside down and/or upset it on one side, but keep it in vertical position or as accorded with the constructor instructions;
- if the stove is made up of ceramic, stone, glass or any particularly fragile material components, all must be moved with the utmost care.

## 3 CHIMNEY FLUE

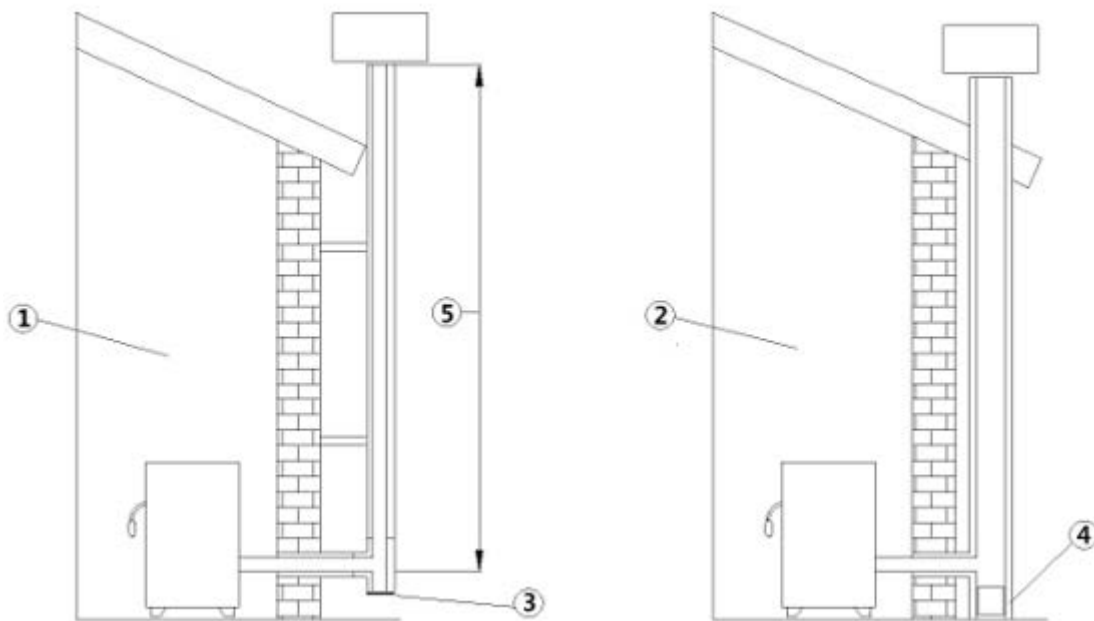


### 3.1 INTRODUCTION

This chapter about the Chimney Flue has been drawn up in cooperation with Assocosma ([www.assocosma.org](http://www.assocosma.org)) and is based on European Standards (EN 15287 - EN 13384 - EN 1856 - EN 1443) and UNI 10683:2012.

It provides instructions for a good and correct execution of the chimney flue but it does not absolutely replace the current standards which the qualified manufacturer/installer should comply with.

### 3.2 CHIMNEY FLUE



**Fig. 2 - Chimney Flues**

LEGEND	Fig. 2
1	Chimney flue with insulated stainless-steel pipes
2	Chimney flue on the existing chimney
3	Inspection plug
4	Inspection door
5	≥ 3,5 mt

- The chimney flue or chimney is of great importance for the correct running of the heating appliance.
- It is fundamental that the chimney flue is perfectly built and always maintained with a perfect efficiency.
- The chimney flue must be sole (see **Fig. 2**) with insulated stainless-steel pipes (1) or installed on the existing chimney flue (2).

- Both this solutions must be endowed with an inspection plug (3) and/or an inspection door (4).

### 3.3 TECHNICAL FEATURES

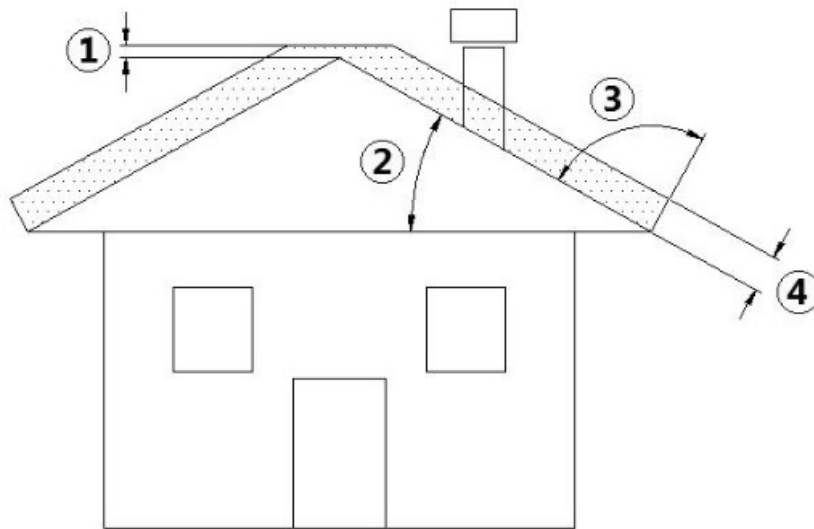


Fig. 3 - Inclined roof

LEGEND	Fig. 3
1	Height over the ridge of the roof = 0,5 mt
2	Roof inclination $\geq 10^\circ$
3	$90^\circ$
4	Measured distance at $90^\circ$ from the roof surface = 1,3 mt

- The chimney flue must be sealed from fumes.
- It must have a vertical run without narrowing. It must be realized with fume and condensation resistant materials with thermal insulation and able to last against usual mechanical stresses.



*It must be insulated to avoid condensation and to reduce fume cooling effects.*

- The stove must be spaced out from fuels or flammable materials with an air gap or with insulating materials. Check the distance with the chimney manufacturer.
- The chimney entrance must be placed in the same room where the appliance is installed or otherwise in the adjacent room and it must be provided with a solid and condensation collection chamber under the entrance, accessible through the sealed metal gate.
- Auxiliary exhaust fans cannot be installed neither along the chimney nor on the chimney pot.
- The inner section of the chimney flue can be round (the best one) or square and the jointed sides must have a minimum radius of 20 mm.
- The section dimension must be:
  - **minimun  $\varnothing 100$  mm**
  - **recommended max  $\varnothing 180$  mm**
- Made the efficiency of the chimney flue overhauled by an expert stove-repairer and if necessary cover the chimney flue with materials in compliance with current regulations.
- The flue system must be placed on the roof.
- The chimney flue must be provided CE in accordance with EN 1443 regulation. Please find attached an example of label:



Fig. 4 - Example of label

### 3.4 HEIGHT-DEPRESSION

The depression (draught) of a chimney flue depends also on its height. Check the depression with the values provided at **FEATURES** a pag. 37. Minimum height 3,5 meters.

### 3.5 MAINTENANCE

- The fumes extraction pipes (fumes conduit + chimney flue + chimney pot) must always be cleaned, scrubbed and checked by an expert stove-repairer, in compliance with current regulations, with the instructions of the stove-manufacturer and the directives of your insurance company.
- In case of doubts, please follow the most restrictive regulations.
- Have your chimney flue and chimney pot checked and cleaned by an expert chimney sweep at least once a week. The chimney sweep has to release a written declaration about the security of the system.
- Not cleaning compromise safety.

### 3.6 CHIMNEY POT

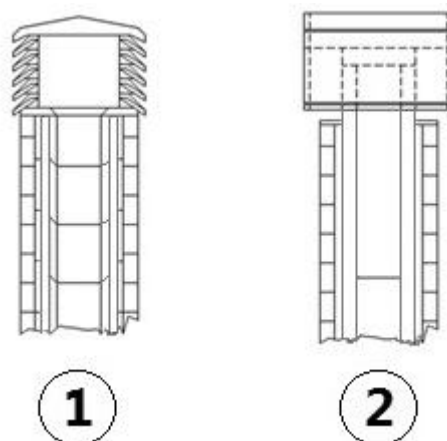


Fig. 5 - Anti-wind chimney pots

The chimney pot is important for the correct running of the heating appliance:

- We recommend using an anti-wind chimney pot, see **Fig. 5**.
- The hole width for fumes exhaust must be the double of the chimney flue width and fitted in a way that the fume exhaust is assured also in case of wind.
- It should prevent the infiltration of rain, snow and animals.
- The outlet height in the atmosphere must be away from the reflux area caused by the roof structure or by obstacles laying nearby (see **Fig. 3**).

### 3.7 CHIMNEY COMPONENTS

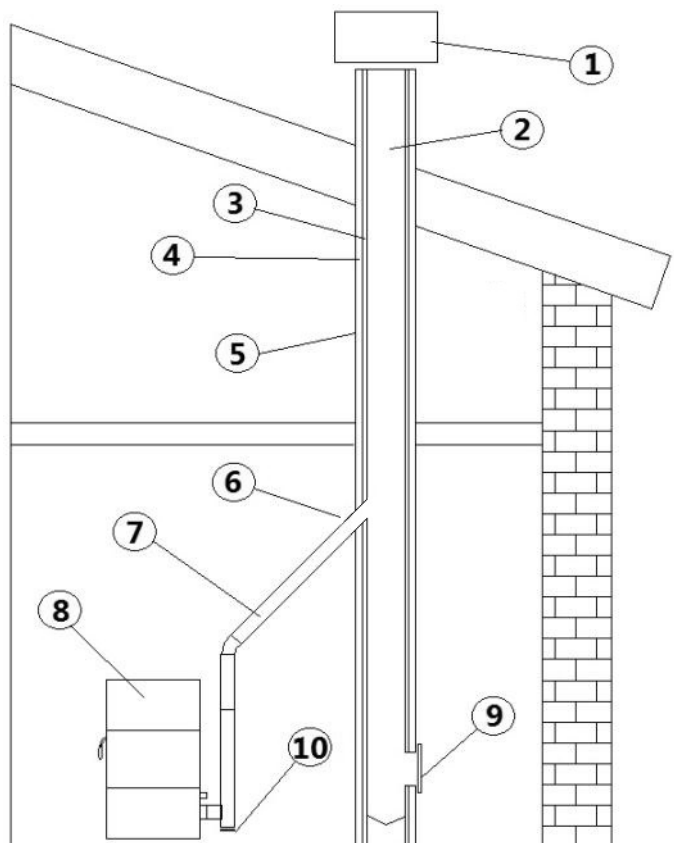


Fig. 6 - Chimney components

LEGEND	Fig. 6
1	Chimney pot
2	Fume outlet
3	Chimney flue
4	Thermal insulation
5	External wall
6	Chimney union
7	Fume pipe
8	Heat generator
9	Inspection door
10	T-union with inspection plug

### 3.8 CHIMNEY FLUE CONNECTION

Your pellet stove works through a fume draught forced by a fan. It is obligatory to check that all pipes are realized in compliance with the following regulation on material selection: EN 1856-1, EN 1856-2 e UNI/TS 11278. All must be effected by specialized personnel or companies as provided by UNI 10683:2012.

- The connection between the appliance and the chimney flue should be short in order to favor the draught and to avoid condensation in the pipes.
- The fume conduit should be equivalent or longer than the outlet joint ones (Ø 80 mm).
- Some stove models are endowed with a lateral and/or back exhaust. Check that the unused exhaust is sealed with the plug given with standard equipment.

SYSTEM TYPE	Ø80 mm PIPE	Ø100 mm PIPE
Minimum vertical length	1,5 mt	2 mt
Maximum length (with 1 union)	6,5 mt	10 mt

SYSTEM TYPE	Ø80 mm PIPE	Ø100 mm PIPE
Maximum length (with 3 unions)	4,5 mt	8 mt
Maximum number of unions	3	3
Level section (minimum inclination 3%)	2 mt	2 mt
Installation at a height above 1200 m a.s.l.	NO	Obligatory

- Use a plate pipe for stoves of Ø80 mm or Ø100 mm depending on the type of system and with silicone gaskets.
- It is forbidden to use metal, fibre cement or aluminium flexible pipes.
- For change of direction it is obligatory always to use a union (with angle > 90°) with inspection plug which enables an easy periodic cleaning of the pipes.
- Please assure you that after the cleaning the inspection plugs are sealed with its efficient gasket.
- It is forbidden to exhaust flue gases directly from the wall towards the outside and closed spaces also at open top.
- The fume conduit must be placed at a distance of minimum 500 mm from flammable or heat-susceptible components.
- It is prohibited to connect more than one wood/pellet (\*) or any other type of appliance (vent cowl...) to the same flue.

(\*) unless there are national derogations (for instance in Germany), which under suitable conditions allow for the installation of several appliances in the same fireplace. In any case, strictly follow the product/installation requirements of the relative regulations/legislation in force in that country.

### 3.9 EXAMPLES OF CORRECT INSTALLATION

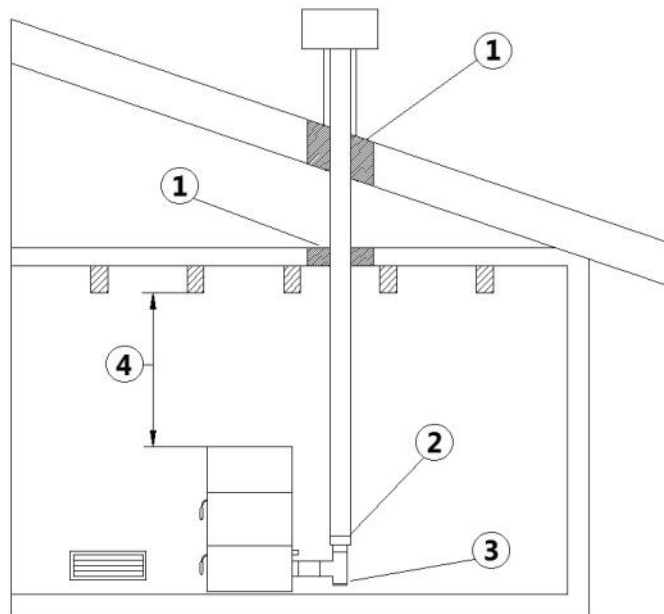
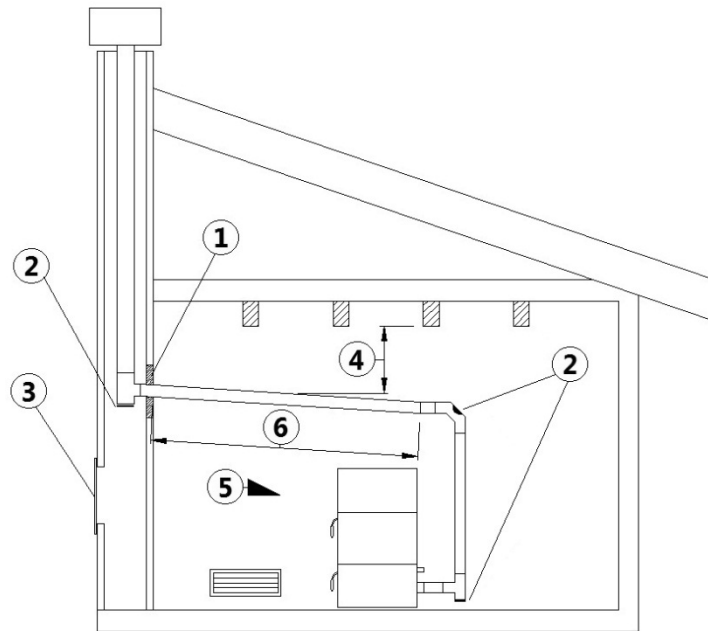


Fig. 7 - Example 1

LEGEND	Fig. 7
1	Insulating material
2	Reduction from Ø100 to Ø80 mm
3	Inspection plug
4	Minimum safety distance = 0,5 mt

- Chimney flue installation Ø100/120 mm with an enlarged drilling for pipe transit.

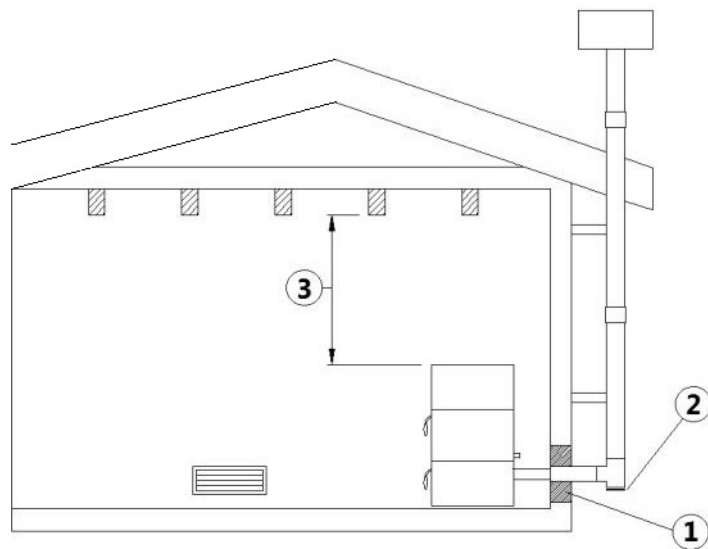




**Fig. 8 - Example 2**

<b>LEGEND</b>	<b>Fig. 8</b>
<b>1</b>	Insulating material
<b>2</b>	Inspection plug
<b>3</b>	Chimney inspection entrance
<b>4</b>	Minimum safety distance = 0,5 mt
<b>5</b>	Inclination $\geq 3^\circ$
<b>6</b>	Level section $\leq 1$ mt

- Old chimney flue with an inserted pipe of minimum  $\varnothing 100/120$  mm and with an external door which enables the chimney cleaning.



**Fig. 9 - Example 3**

<b>LEGEND</b>	<b>Fig. 9</b>
<b>1</b>	Insulating material
<b>2</b>	Inspection plug
<b>3</b>	Minimum safety distance = 0,5 mt

- External chimney flue entirely made up of insulated stainless steel pipes, i.e. with double wall of minimum  $\varnothing 100/120$  mm: all must be firmly attached to the wall. For chimney against wind effects please (see **Fig. 5**).
- Ducting system through T-unions which enables an easy cleaning without disassembling the pipes.



We recommend to check with your chimney flue manufacturer the safety distances which must be respected and the type of insulating material. The aforesaid regulations are valid also for holes made on the wall (EN 13501 - EN 13063 - EN 1856 - EN 1806 - EN 15827).

## 4 COMBUSTION AIR

### 4.1 EXTERNAL AIR INLET

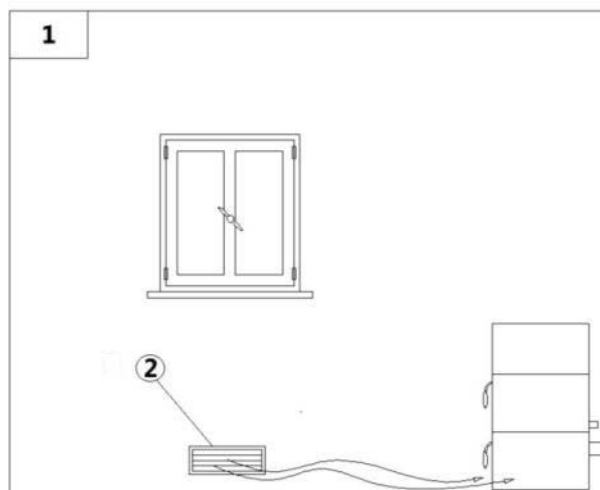


Fig. 10 - Direct air inflow

LEGEND	Fig. 10
1	Room to ventilate
2	External air inlet

- The room must be endowed with an external air recycling for a good climate in your ambient.
- The air inflow from outside to the inner occurs directly, through an opening on the external wall of the room (see **Fig. 10**).
- Bedrooms, garages, and store of flammable materials are excluded.
- The air inlet should have a total net surface of 80 sqcm<sup>2</sup>: the aforesaid surface is to widen if inside the room there are other activated appliances (for example: electric ventilators for foul air suction, cooker hoods, other stoves, etc...) which depress the environment.
- At switched on appliance it is necessary to check that the pressure fall between the room and the outside does not exceed 4,0 Pa value: if necessary widen the air inlet (EN 13384).
- The air inlet must be realized at a height close to the floor with an external grid against birds. In such a way it cannot be obstructed by any object.
- **In case of installation with sealed-chamber the air inlet is not necessary.**

## 4.2 COMBUSTIBLE AIR INLET FOR SEALED-CHAMBER INSTALLATION

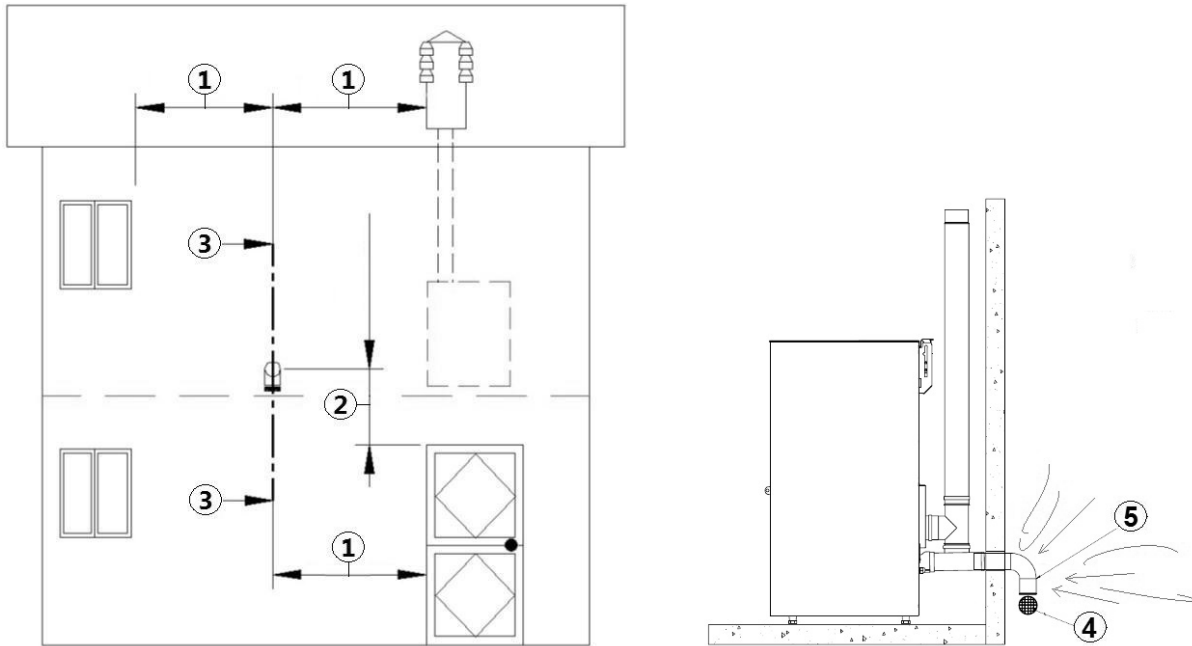


Fig. 11 - Air inlet for sealed-chamber installation

LEGEND	Fig. 11
1	$\geq 1,5 \text{ mt}$
2	$\geq 0,3 \text{ mt}$
3-3	Sectional view
4	Shield grid
5	Curve inlet to turn downwards

Check if the purchased stove has a sealed-chamber. If the stove is endowed with a sealed-chamber and you want also the whole installation with sealed chamber, please read the following instructions:

- It is necessary to extract the air for combustion directly from outside.
- Use a tube with minimum  $\text{Ø}60 \text{ mm}$  and maximum 2 meters length; to connect see the back of the stove.
- French standards require installation in double-walled flues (concentric system). The combustion air is drawn from the cavity.
- During installation step is necessary to verify the minimum distances required for the combustible air inlet as (for example) an open door or window causes a vortex which could remove the combustible air necessary to the stove (see the underlying scheme).
- On the external wall it is necessary to install a curve at  $90^\circ$  to protect the combustible air inflow from wind effects: turn the curve inlet downwards, see **Fig. 11**.
- Endow the curve with an external shield grid against birds in such a way that it cannot be obstructed by any object.



*Check with your local authorities if exists any restrictive regulation regarding the combustible air inlet: if present, they must be applied*



*In some countries and/or regions the installation with sealed-chamber is obligatory: in case of doubt, please follow the most restrictive regulations.*

## 4.3 COMBUSTIBLE AIR INLET FOR SEALED-CHAMBER INSTALLATION

How to connect to the stove in the sealed chamber with concentric system:

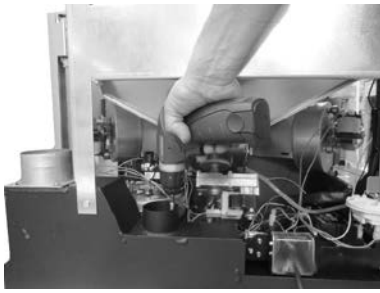


Fig. 12 - Phase 1



Fig. 13 - Phase 2

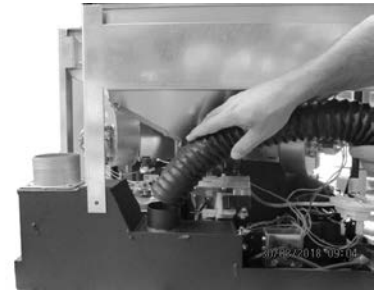


Fig. 14 - Phase 3

- Remove the ring inside the combustion air fitting (see **Fig. 12** and **Fig. 13**).
- Insert the concentric pipe as in **Fig. 14**.

## 5 INSTALLATION

### 5.1 INTRODUCTION

- The assembly position must be chosen depending on environment, outlet, chimney flue.
- Check with local authorities if there are any restrictive regulations which regard the combustible air inlet, room ventilation, fume exhaust system together with chimney flue and chimney pot.
- Check if there is the combustible air inlet.
- Check the probable presence of other stoves or appliances which could depress the room.
- Check at switched on stove if there is the presence of CO in the room.
- Check if the chimney has the necessary draught.
- Check if during the fume passage all has been executed in safety (probable fume losses and distances from flammable materials, etc...).
- The installation of the appliance must enable an easy access for appliance, fume exhaust pipes and chimney flue cleaning.
- The installation must enable an easy access to the electric connection plug (see **ELECTRIC CONNECTION** a pag. 19).
- To install more appliances, the external air inlet must be correctly dimensioned (see **FEATURES** a pag. 37).

### 5.2 OVERALL DIMENSIONS

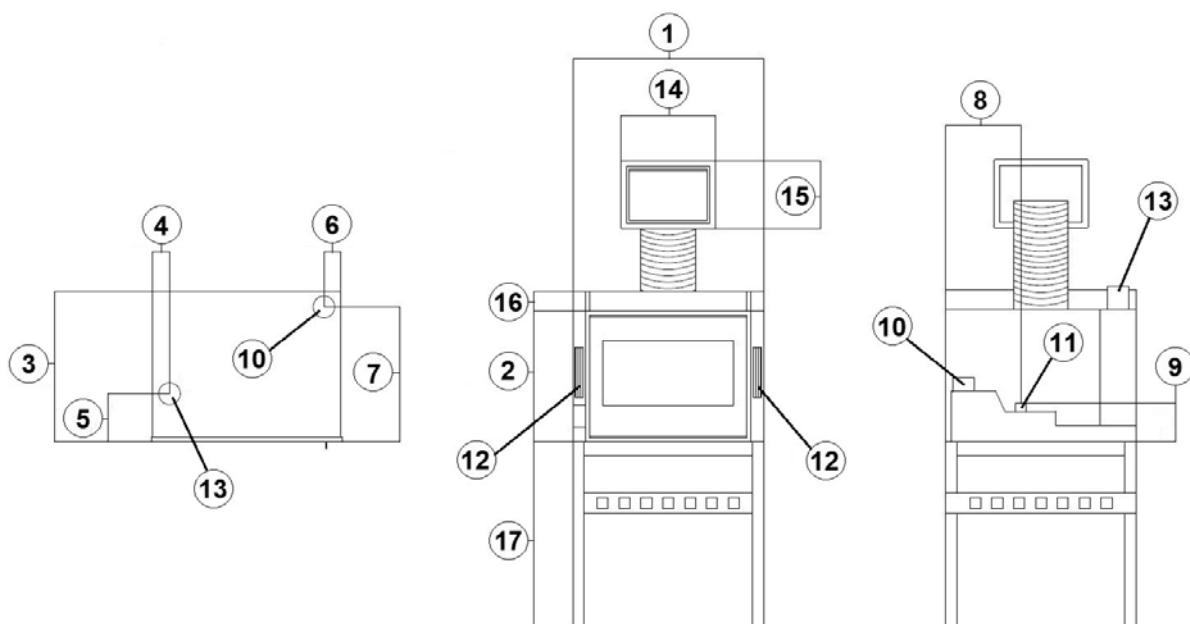


Fig. 15 - General dimensions: Zefiro<sup>3</sup>, Zen Airtight

**LEGEND** Fig. 15

1	69,7 cm
2	49 cm

LEGEND	Fig. 15
3	55 cm
4	6,2 cm
5	17,7 cm
6	6,1 cm
7	49,4 cm
8	25,8 cm
9	14,5 cm
10	Exhaust fumes d.8 cm
11	Hole combustion air inlet d.6 cm
12	Hot air outlet 18x3 cm
13	Ducting outlet d.8 cm (optional)
14	37,7 cm
15	27,2 cm
16	7,5 cm
17	54÷72 cm

### 5.3 GENERAL INSTALLATION

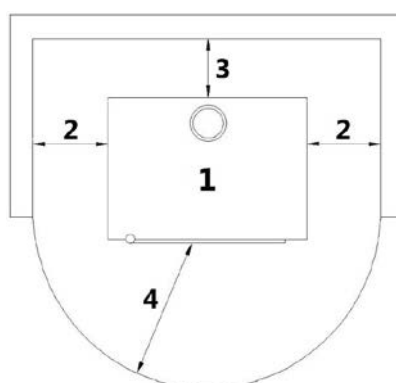


Fig. 16 - General installation

LEGEND	Fig. 16
1	Fireplace insert
2	Minimum lateral distance = 240 mm
3	Minimum rear distance = 190 mm
4	Minimum front distance = 1000 mm
5	Minimum thickness of insulating material = 40 mm

- Please check that the floor has an adequate load capacity. If the existing one does not satisfy this requirement, appropriate measure should be provided (for example a plate for distributing the load).
- It is obligatory to install the stove away from walls and/or pieces of furniture, with a minimum air flow of 240 mm on the sides and 190 mm on the back, to enable an efficient appliance cooling and a good distribution of heat in the room (see **Fig. 16**).
- For safety fire regulations the distances from flammable or sensible to heat objects (sofas, pieces of furniture, wooden covering, etc...) must be respected, as described in **Fig. 16**.



The probable insulating material to use must have the following technical features:

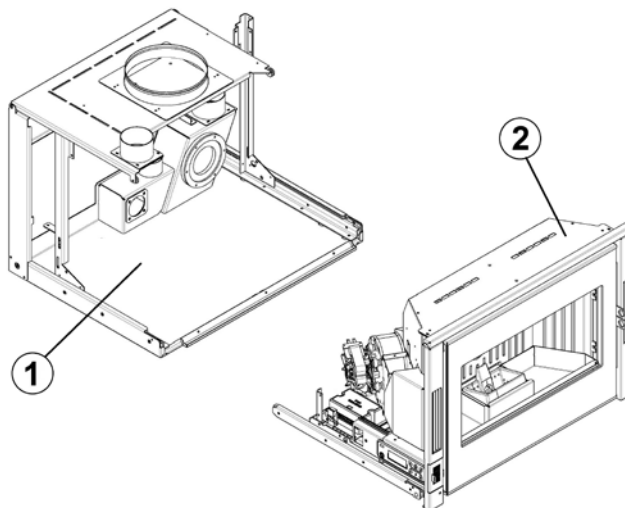
DESCRIPTION	VALUE
Material thickness	40 mm

DESCRIPTION		VALUE
Screening temperature		1000 °C
Density		245 Kg/m <sup>3</sup>
Shrinkage at referring temperature (12h)		1,3 % /1000 °C
Cold crushing strenght		1,4 MPa
Bending strenght		0,5 MPa
Thermal expansion coefficient		5,4x10 <sup>-6</sup> m/mK
Specific heat		1,03 Kj/kgK
Thermal conductivity at medium temperature	200 °C	0,07 W/mK
	400 °C	0,10 W/mK
	600 °C	0,14 W/mK
	800 °C	0,17 W/mK

- If there are highly flammable objects (curtains, fitted carpet, etc...), all these distances must be further increased with 1 meter.
- If the floor is made up of flammable material two solutions are possible:
  - build a protection (steel plate, refractory, marble...) made up of no flammable material;
  - otherwise the insert must be raised at a minimum height of 200mm from the floor (adjusting legs' lenght).
- If the walls are made up of flammable materials, check the safety distances (see **Fig. 16**).
- At maximum power check that the wall temperature does not ever exceed 80°C. If it would be necessary please install a fire resistant plate on the concerned walls.
- In some countries also masonring load-bearing walls are considered flammable.

## 5.4 INSERT EXTRACTION

The insert is composed of:



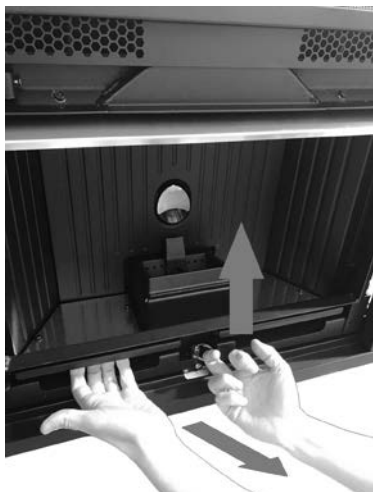
**Fig. 17 - Structure + machine body**

Key	Fig. 17
1	Structure
2	Machine body

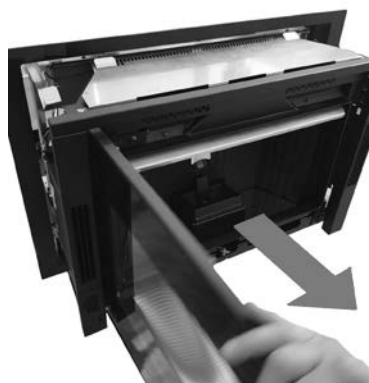
Proceed as follows to extract the insert:

- Open the door.

- Lift the hook (vedi **Fig. 18**) and pull the machine body firmly towards you (see **Fig. 19**).
- Once the machine body has been extracted, you can access the pellet tank.



**Fig. 18 - Lift hook**



**Fig. 19 - Machine body extraction**

## 5.5 INSERT REMOVAL

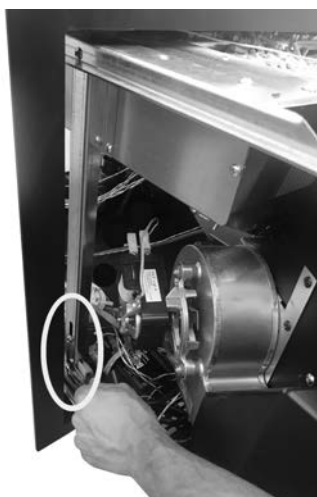


*If the insert is inserted on the guides, there is a danger of tipping over!*

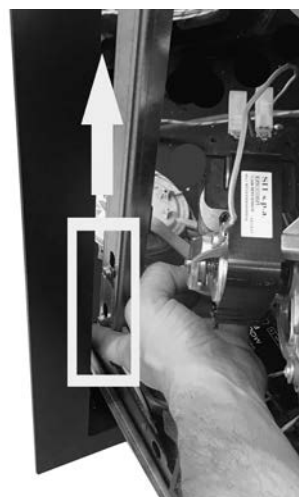


*Assembly operations must always be carried out by 2 people!*

- Pull out the machine body from the structure (see **INSERT EXTRACTION a pag. 14**).
- Loosen the 2 hex screws on both sides of the insert (see **Fig. 20**).
- Lift the safety plate locking the guide open (see **Fig. 21**).



**Fig. 20 - Loosen screws**



**Fig. 21 - Lift locking plate**

- Using the supplied handles (see **Fig. 22**) place them in the appropriate seats (see **Fig. 23**) and remove the machine body from the guides.
- To reassemble it proceed in reverse order.



Fig. 22 - Handle



Fig. 23 - Machine body removal

## 5.6 INSTALLATION WITH EXTERNAL COVER

- It is possible to cover the insert with your liking cover respecting the correct execution as described in **GENERAL INSTALLATION a pag. 13** and following the under mentioned instructions.
- Fix the legs (optional) to the floor and lift the insert frame till the desired height by adjusting the legs and then block it with screws on the fitting guides.
- It is obligatory to fix the supporting frame legs at the base with metal plugs able to bear a weight of 50 kg for leg.



*In case of insert extraction fixed on guides there is the risk of overturning!  
Check if the insert frame is fixed to the floor.*

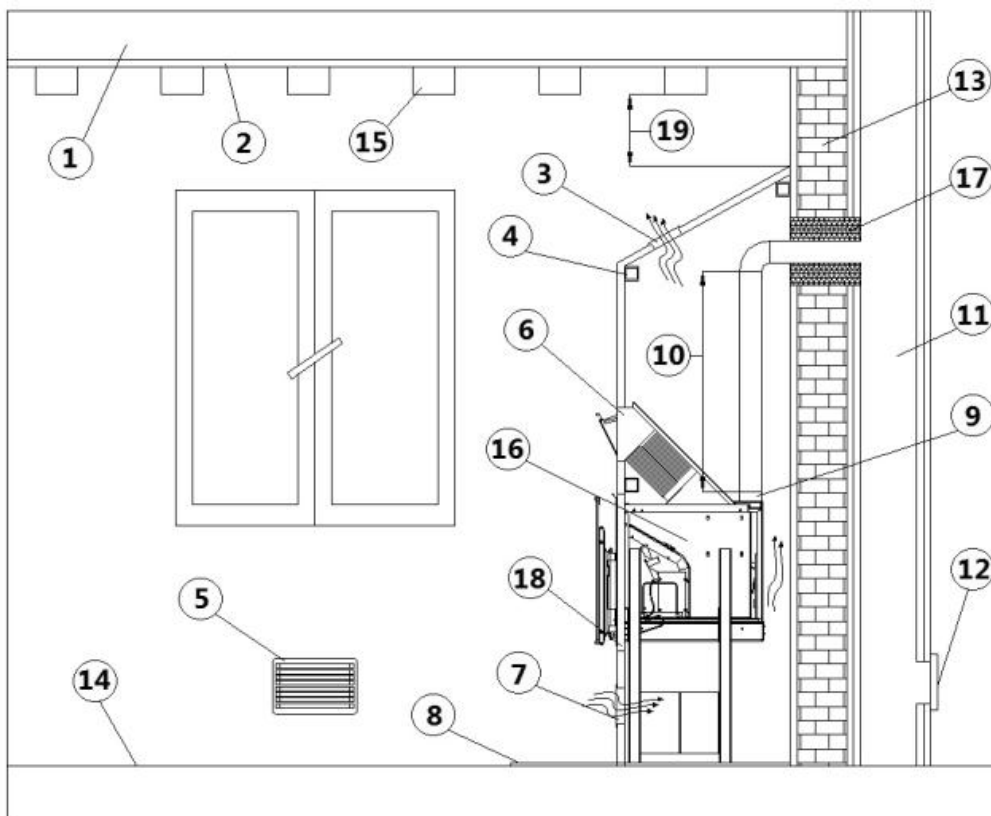


Fig. 24 - Installation with cover

### LEGEND Fig. 24

1	Ceiling to protect
---	--------------------



<b>LEGEND</b>	<b>Fig. 24</b>
<b>2</b>	Ceiling plaster to protect from heat
<b>3</b>	Ventilation grid with a minimum entrance of 400 cm <sup>2</sup> for natural hot convective air outlet
<b>4</b>	Self-supporting metal frame
<b>5</b>	Combustible air outlet
<b>6</b>	Pellet load entrance
<b>7</b>	Lower air grid with a minimum entrance of 400 cm <sup>2</sup> for natural cool convective air inlet
<b>8</b>	Floor protecting plate
<b>9</b>	Outlet clutch Ø80 mm
<b>10</b>	Fume pipe Ø80 mm with a minimum vertical length of 1 mt
<b>11</b>	Chimney flue of minimum Ø120 mm
<b>12</b>	Sealed chimney flue's inspection door
<b>13</b>	Wall
<b>14</b>	Floor
<b>15</b>	Ceiling with wooden beam
<b>16</b>	Fireplace insert
<b>17</b>	Insulating between wall and fume pipe of minimum 200 mm on the whole diameter
<b>18</b>	Combustible air inlet
<b>19</b>	Minimum distance between the wooden beams and the fume pipe = 0,5 mt

- Build a metal frame for supporting cover panels (4).
- Do not discharge the metal structure weight on the insert frame.
- Cover the metal frame with panels made up of no flammable materials.



Made a cleft of min. 400 cm<sup>2</sup> on the lower (7) and upper (3) parts of the panels for the inner air recycling.

- The pellet loading can occur by extracting the insert at switched off appliance, otherwise through the installation of a loading trap door (6).
- The loading trap door can be frontally or laterally installed, extending the flexible pipe Ø160 mm according to your needs.

## 5.7 INSTALLATION ON EXISTING FIREPLACE

- It is possible to build the insert into an existing fireplace respecting the distances and the correct execution as described by **GENERAL INSTALLATION a pag. 13** and following the below mentioned instructions.
- Fix the legs (optional) at the lowest height and block them with screws on its fitting guides.
- It is obligatory to fix the leg of the supporting frame at the base with metal plugs able to bear a weight of 50 kg for leg.



In case of fixed on guides insert extraction there is the risk of overturning!  
Check if the insert frame is correctly fixed to the base.

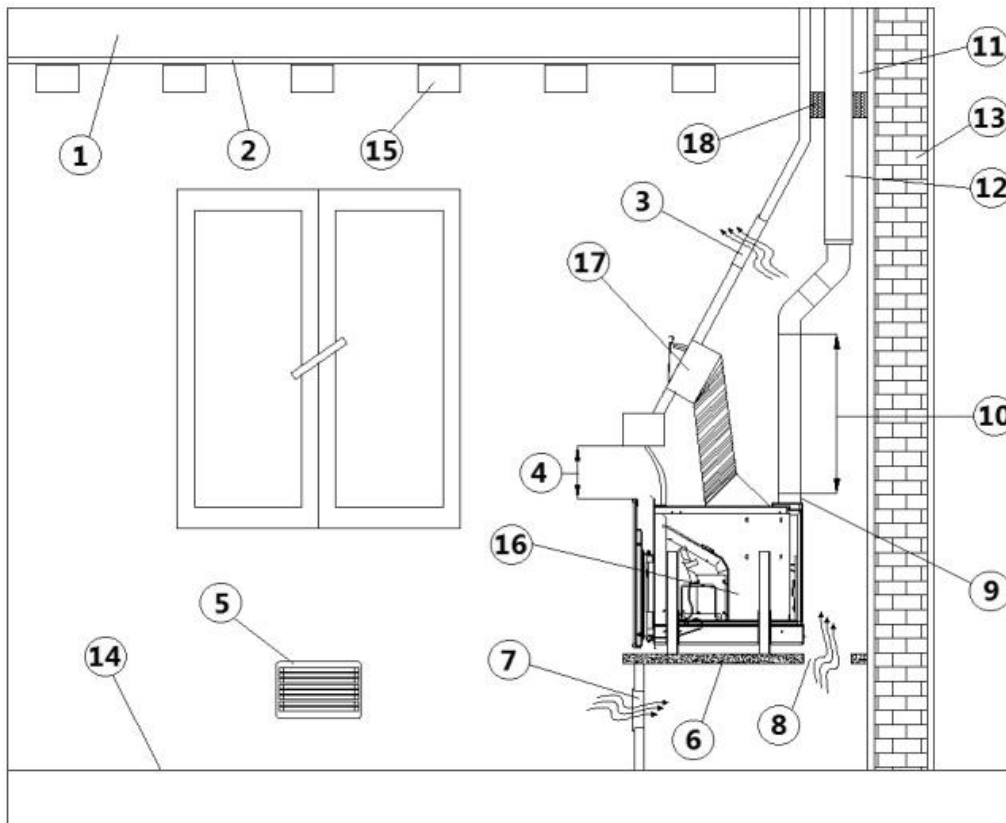


Check if the upper hot air outlet is not choked, see **Fig. 25**.



Make a cleft of 400 cm<sup>2</sup> on the lower and upper part of the fireplace for the inner air recycling.

- The pellet loading can occur by extracting the insert at switched off appliance, otherwise through the installation of a loading trap door (6).
- The loading trap door can be frontally or laterally installed, extending the flexible pipe Ø160 mm according to your needs.



**Fig. 25 - Installation on the existing fireplace**

**LEGEND Fig. 25**

<b>1</b>	<i>Ceiling to protect</i>
<b>2</b>	<i>Ceiling plaster to protect from heat</i>
<b>3</b>	<i>Ventilation upper grid minimum entrance 400 cm<sup>2</sup> for natural hot convective air outlet</i>
<b>4</b>	<i>Hot air deflector</i>
<b>5</b>	<i>Combustible air inlet</i>
<b>6</b>	<i>Fireplace's fire plate</i>
<b>7</b>	<i>Lower air grid with minimum entrance 400 cm<sup>2</sup> for natural cool convective air inlet</i>
<b>8</b>	<i>Ventilation cleft of 400 cm<sup>2</sup> for convective cool air recycling</i>
<b>9</b>	<i>Outlet clutch Ø80 mm</i>
<b>10</b>	<i>Fume pipe Ø80 mm with minimum vertical length of 1 mt</i>
<b>11</b>	<i>Chimney flue &gt; Ø120 mm</i>
<b>12</b>	<i>Fume pipe Ø100 mm</i>
<b>13</b>	<i>Wall</i>
<b>14</b>	<i>Floor</i>
<b>15</b>	<i>Ceiling with wooden beams with a minimum distance from the fume pipe = 0,5 mt</i>
<b>16</b>	<i>Fire place insert</i>
<b>17</b>	<i>Pellet loading entrance</i>
<b>18</b>	<i>Locking ring</i>

## 5.8 DOOR ADJUSTMENT

To centre the door, proceed as follows:



**Fig. 26 - Door adjustment**

- Open the door.
- Loosen the two front screws in the upper hinge and, using the side screw (the one circled in the picture) adjust the door forward or backward (see **Fig. 26**).
- Once the door is centred, lock the 2 front screws.

## 5.9 ELECTRIC CONNECTION



*Warning: the appliance must be installed by an authorized technician!*

- The electric connection occurs through a cable with plug put in an electric socket which is able to support charge and tension specific of every model, as described in the technical datas table (see **FEATURES a pag. 37**).
- The plug must be easily accessible when the appliance is installed.
- Please further assure you that your network is endowed with an efficient earth connection: if it does not exist or if it is not efficient, please endow you with one in compliance with the law.
- Connect the supply cable first on the back of the stove (see **Fig. 27**) and then at a wall electric socket.



**Fig. 27 - Electric socket with master switch**

- The master switch 0/I (see **Fig. 27**) is to open only to switch the stove on, otherwise it is advisable to keep it off.
- Do not use extension cables.
- If the feeder cable is damaged, it must be replaced by an authorized technician.
- When the stove is not going to be used for a long period of time, it advisable to remove the plug from the socket on the wall.

## 5.10 CONNECTION TO THE EXTERNAL THERMOSTAT

The stove is already working by means of a thermostat probe positioned inside it.

We strongly recommend connecting the insert to an external thermostat, as the room probe may not work properly in the presence of high temperatures (given the close distance to the combustion chamber).

This operation must be performed by an authorised technician.

Connect the wires from the external thermostat to the "Term opt" terminal on the stove board. Activate the external thermostat

(default setting OFF) as indicated below:

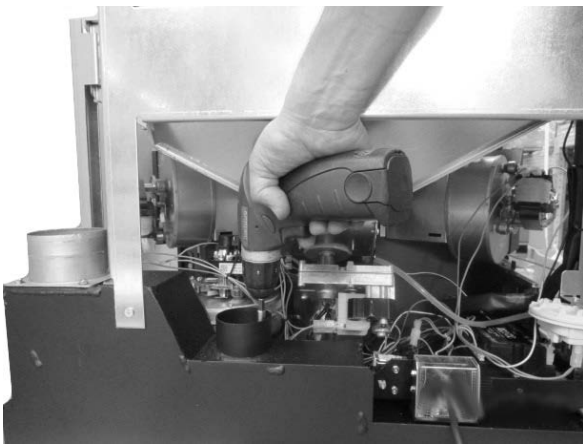
- Press the "menu" button.
- Scroll with the arrows to "Settings".
- Select by pressing "menu".
- Scroll with the arrows again to "Ext.Thermostat".
- Select by pressing "menu".
- Press the - + buttons.
- To activate the external thermostat select "on".
- Press the "menu" button to confirm.

## 5.11 AIR REGULATOR

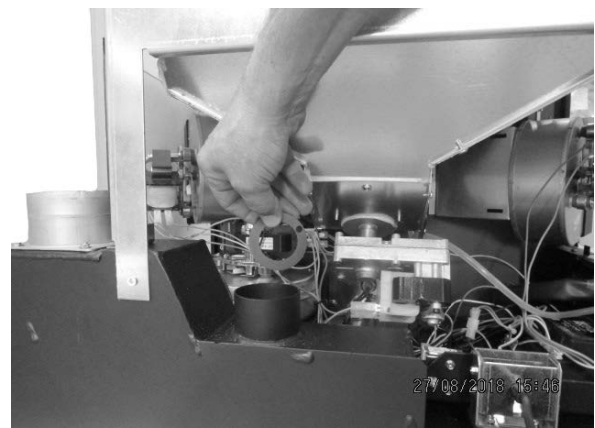
The stove is fitted with a removable rear air regulator

The stove is regulated according to the flue data and pellet used, as per the technical features (see **FEATURES a pag. 37**)

If the data does not match, the authorised technician can increase the stove draft by removing/loosening the ring located inside the air inlet pipe (see **Fig. 28** and **Fig. 29**).



**Fig. 28 - Ring removal 1**



**Fig. 29 - Ring removal 2**

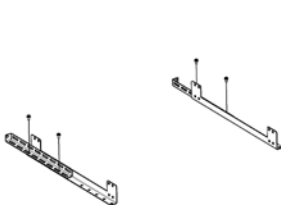
Air regulator opening 35 mm for nominal power with flue 11 Pa.

## 5.12 INSERT LEGS INSTALLATION (OPTIONAL)

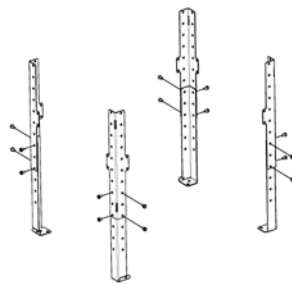
It is possible to install the insert on a support structure with height-adjustable legs.

To assemble the legs, proceed as follows:

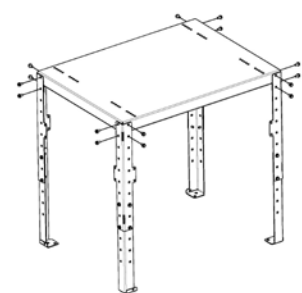
- Fix the leg reinforcement with the extension using the screws (see **Fig. 30**).
- Compose the 4 legs and fix them with the screws (see **Fig. 31**).
- Fix the insert support surface above the legs (see **Fig. 32**).



**Fig. 30 - Assemble reinforcement + extension**



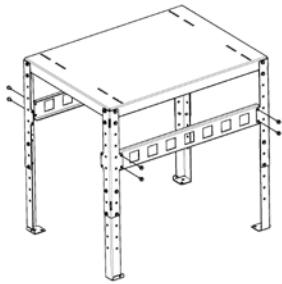
**Fig. 31 - Assemble legs**



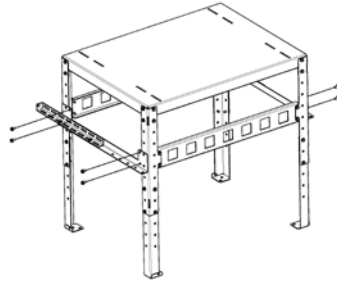
**Fig. 32 - Assemble legs + surface**

- Fix the 2 reinforcement crosspieces of the structure (see **Fig. 33**).
- Also fix the reinforcements + the extensions assembled previously (see **Fig. 34**).

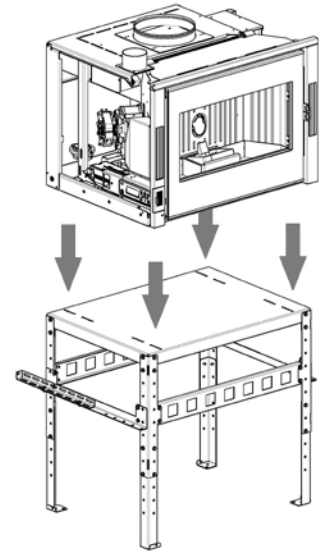
- Place the insert above the structure, fixing it with the screws in the appropriate seats (see **Fig. 35**).



**Fig. 33 - Assemble reinforcements**

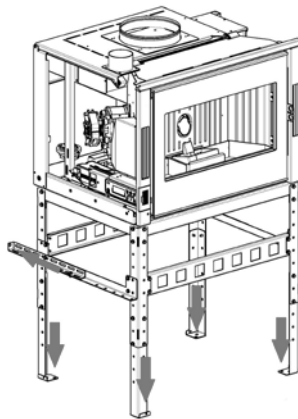


**Fig. 34 - Assemble reinforcements + extensions to the structure**



**Fig. 35 - Fix insert above to the structure**

- Position the structure with the insert as desired and fix the legs to the floor and the extensions to the wall behind (see **Fig. 36**).



**Fig. 36 - Fix the structure to the floor and wall**

## 5.13 HOT AIR DUCTING (OPTIONAL ONLY FOR ZEFIRO)



WITH THE INSTALLATION OF THE DUCTING, IT IS NECESSARY TO LOAD THE NEW DATABASE IN THE BOARD (DATABASE NO.02).  
SEE "SERVICE MANUAL".

By default, the insert inserts the hot air into the environment from both the front vents. It is possible to channel the left air on the back of the stove, through a ducting kit.

To assemble the kit, proceed as follows:

- Extract the machine body.
- Remove the 4 fixing screws of the left fan (see **Fig. 37**).
- Use a clamp to break the corner of the casing (see **Fig. 38**) and bend the flap inwards with your hands (see **Fig. 39**).



**Fig. 37 - Remove the fan**

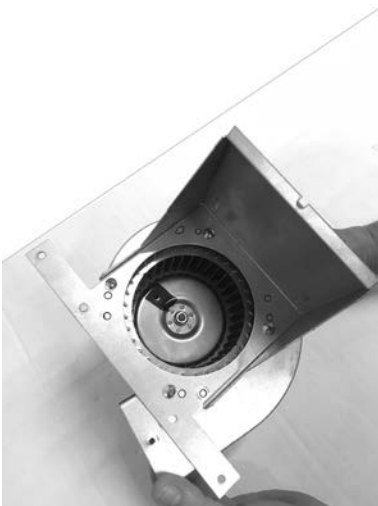


**Fig. 38 - Break the corner**



**Fig. 39 - Fold the flap**

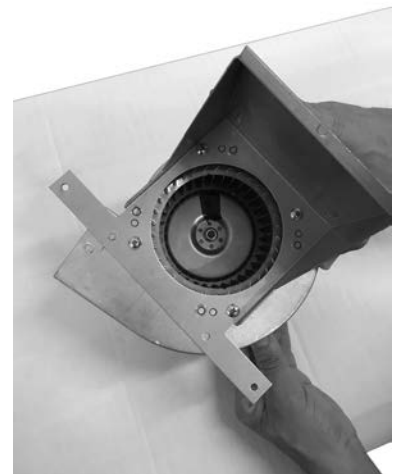
- Place the fan and casing on a surface (see **Fig. 40**).
- Loosen the 4 screws (see **Fig. 41**) and rotate the casing and retighten the screws in the new position. Pay attention to the position of the holes (see **Fig. 42**).



**Fig. 40 - Fan + casing**



**Fig. 41 - Remove the screws**



**Fig. 42 - Rotate the fan**

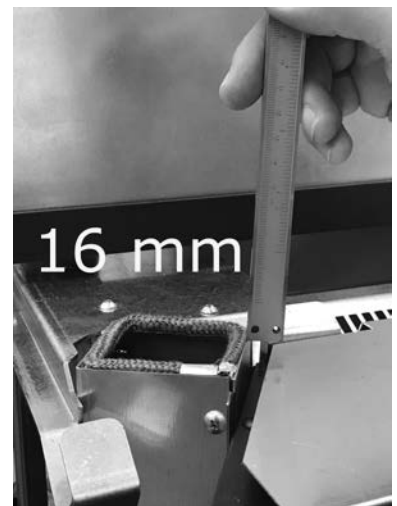
- Insert the air diverter temporarily as shown in the picture **Fig. 43**.
- Fit the new fan + casing in the new position and secure the screws (see **Fig. 44**).
- Then align the diverter with the holes in the boiler. Attention: the air diverter must protrude about 16 mm above the machine body (see **Fig. 45**).



**Fig. 43 - Position the air diverter**



**Fig. 44 - Secure the fan**



**Fig. 45 - Projection of the air diverter**

- Seal the joint between the fan and the diverter with adhesive aluminium tape (see **Fig. 46**).

- Mount the fitting on the air diverter for the air to be ducted (see **Fig. 47**).
- Connect the ducting pipe d.80 and block the pipe with the clamp. Attention: use at least 20 cm of flexible pipe above the fitting since the cover of the insert moves during manoeuvres (see **Fig. 48**).



**Fig. 46 - Seal with adhesive aluminium tape**



**Fig. 47 - Secure the fitting**



**Fig. 48 - Flexible pipe connection (rear view of the insert)**



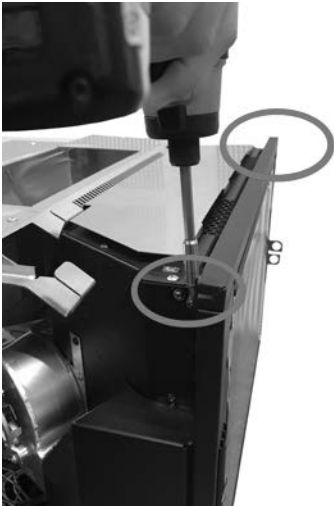
**Fig. 49 - Example of ducting**

- A stove with no ducting has a variable air flow rate from a minimum of 61 m<sup>3</sup>/h to a maximum of 130 m<sup>3</sup>/h, and an air temperature which varies from a minimum of 90°C to a maximum of 136°C.
- In the case of ducting, it is recommended not to exceed 6 metres of pipe and 3 x 90° bends, otherwise the hot air loses its effectiveness.
- Use pipes with an 80 mm diameter with smooth internal walls.
- If the pipes pass through cold walls, insulate the pipe with insulating material.
- Place a protective grille with large mesh and a total minimum net surface area of 40 cm<sup>2</sup> over the outlet.
- After the 6 metres of pipe there can be a variable air flow rate from a minimum of 58 m<sup>3</sup>/h to a maximum of 83 m<sup>3</sup>/h, and an air temperature which varies from a minimum of 65°C to a maximum of 99°C. (These values have been recorded in the laboratory, there may be differences in both flow rate and temperature in the installation room).
- If you wish to increase the air flow, install a small wall-mounted fan on the outlet with a flow rate of more than 130 m<sup>3</sup>/h, this should be performed by an authorised technician.
- With factory parameters 1/2 of the heat produced by the stove is conveyed into the room where it is installed, the remaining 1/2 comes out from the ducting on the left.

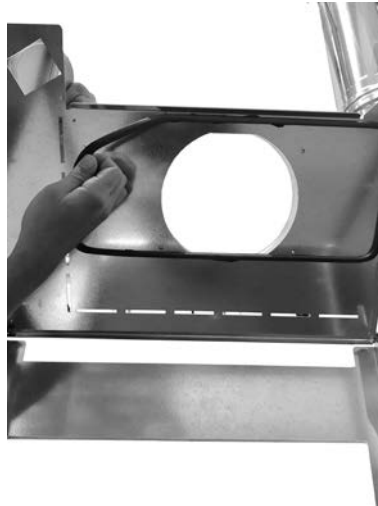
- To get the best performance you need to balance the power with the air flow. This operation must be performed with the assistance of an authorised technician.
- The ductable fans cannot be deactivated, but they can be operated at a power value between 1 and 5 or in automatic mode.

## 5.14 PELLET DRAWER INSTALLATION (OPTIONAL ONLY FOR ZEFIRO)

The insert is designed for loading the pellet through a drawer.  
 Proceed as follows to assemble:



**Fig. 50 - Upper profile removal**

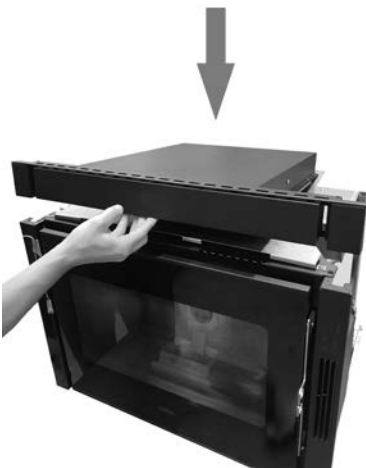


**Fig. 51 - Gasket removal**



**Fig. 52 - Gasket positioning**

- Remove the insert from the machine body.
- Remove the upper profile above the door (see **Fig. 50**).
- In the structure, remove the silicone gasket under the cover (see **Fig. 51**) and place it under the pellet loading drawer (see **Fig. 52**).



**Fig. 53 - Drawer positioning**



**Fig. 54 - Drawer front fixing**



**Fig. 55 - Drawer central fixing**

- Position the drawer above the machine body (see **Fig. 53**) and fix the front part first (see **Fig. 54**) then the central part (see **Fig. 55**).





**Fig. 56 - Adjustment for centring**

- If necessary, remove the drawer and adjust, using the 2 wheels on the guides, its centring (see **Fig. 56**).

### INSERT WITH DRAWER WITHOUT DUCTING



**Fig. 57 - Remove the cover**



**Fig. 58 - Insert insertion**

- Completely remove the cover from the structure (see **Fig. 57**).
- Position the machine body with the pellet drawer in the structure (see **Fig. 58**).

### INSERT WITH DRAWER AND WITH DUCTING



**Fig. 59 - Cover cut**



**Fig. 60 - Insert insertion**

- Following the precuts, cut the indicated part using an angle grinder/hacksaw (see **Fig. 59**) and then remove it.
- Position the machine body with the pellet drawer in the structure (see **Fig. 60**) and proceed with the connection of the air

ducting pipe (see dedicated chapter).

## 5.15 TRAPDOOR INSTALLATION (OPTIONAL)

The insert is designed for loading the pellet through a trapdoor.

The hole in the wall where it will house the trapdoor must have the following dimensions:

**L = 34 cm**

**H = 23.5 cm**

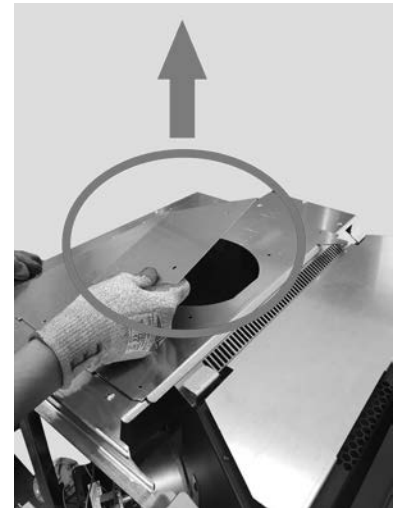
Proceed as follows to assemble:



*Fig. 61 - Fix the flexible hose*



*Fig. 62 - Tighten the clamp*



*Fig. 63 - Remove the cap*

- Fix the flexible hose to the trapdoor base (see **Fig. 61**) with the metal clamp (see **Fig. 62**).
- Remove the cap from the structure cover (see **Fig. 63**).



*Fig. 64 - Flexible hose positioning*

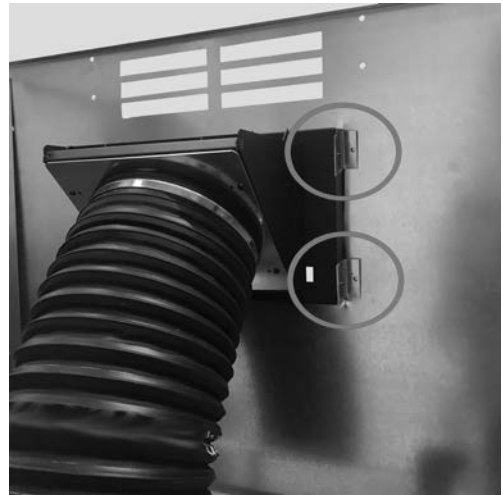


*Fig. 65 - Flexible hose fixing*

- Pass the flexible hose inside the hole made in the wall (see **Fig. 64**).
- Fix the pipe end flange to the structure cover, where the cap was previously removed (see **Fig. 65**).



**Fig. 66 - Trapdoor external fixing**



**Fig. 67 - Trapdoor internal fixing**

- Fix the trapdoor to the door, both internally and externally (see **Fig. 66** and **Fig. 67**).



**Fig. 68 - Insert the door in the trapdoor**



**Fig. 69 - Correct hooking of the hinge**

- Hook the door to the trapdoor (see **Fig. 68**). **Make sure that the hinge is in the correct position** (see **Fig. 69**).



**Fig. 70 - Safety lever**



**Fig. 71 - Door closed**

- Rotate the safety levers to lock the hinges (see **Fig. 59**).
- Close the door (see **Fig. 71**). The trapdoor is ready to be used.

## 5.16 FRAME INSTALLATION (OPTIONAL)

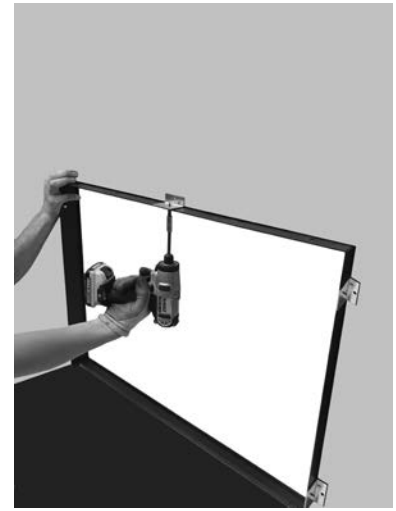
It is possible to insert a compensation/decorative frame around the insert. Proceed as follows to mount:



*Fig. 72 - Front fixing*



*Fig. 73 - Rear fixing 1*



*Fig. 74 - Rear fixing 2*

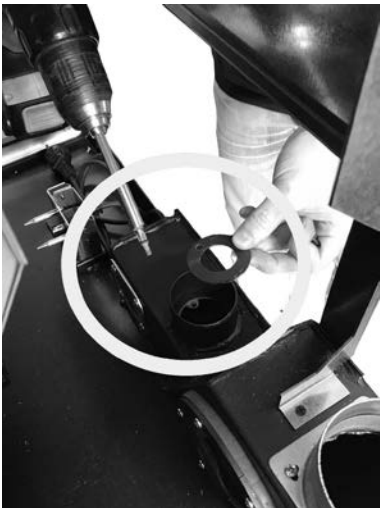
- Remove the insert from the structure.
- Loosen the 2 hex screws on the base of the structure, fit the frame and tighten the screws again (see **Fig. 72**).
- Fix the frame inside the wall using the supplied flange (see **Fig. 73** and **Fig. 74**).
- Insert the insert inside the structure again.

## 5.17 CONCENTRIC PIPE INSTALLATION (OPTIONAL)

The insert is designed for the connection of the concentric pipe.

Proceed as follows to assemble:

- Remove the ring inside the combustion air fitting (see **Fig. 75**).
- Insert the concentric pipe as in **Fig. 76**.
- Insert the combustion air fitting (see **Fig. 77**).



*Fig. 75 - Remove the ring*



*Fig. 76 - Concentric pipe connection*

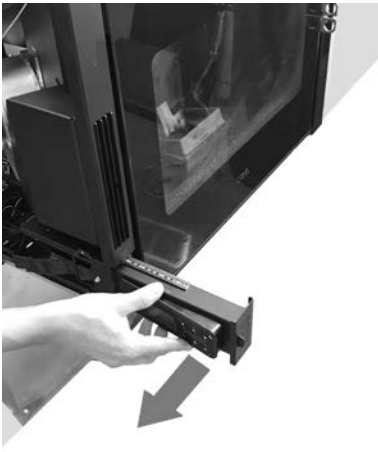


*Fig. 77 - Combustion air connection*

## 5.18 DISPLAY ROTATION

By default, the display faces left.

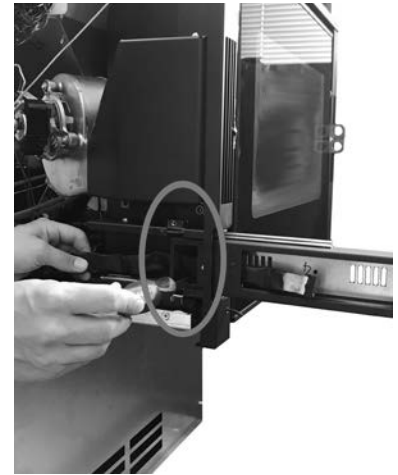
Proceed as follows to have the display face right:



**Fig. 78 - Remove the display**



**Fig. 79 - Remove the flat cable**

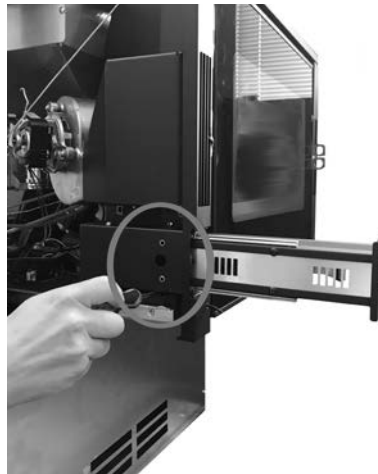


**Fig. 80 - Remove the screws**

- Completely remove the door containing the display.
- Remove the display (see **Fig. 78**) and disconnect the flat cable to which it is connected (see **Fig. 79**).
- Remove the 2 screws from the display box (see **Fig. 80**).



**Fig. 81 - Rotate the display box**



**Fig. 82 - Secure the screws**

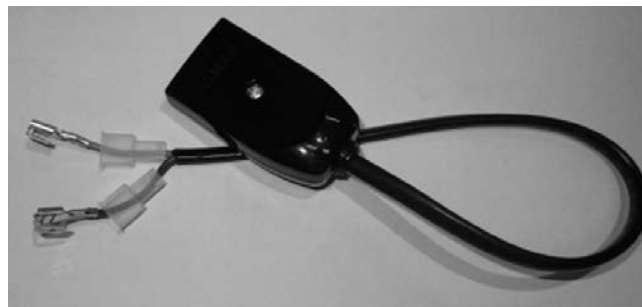


**Fig. 83 - Connect and reposition the display**

- Pull the display box back and turn it in the other direction (see **Fig. 81**).
- Fix the box in the new position (see **Fig. 82**).
- Reconnect the flat cable and reposition the display (see **Fig. 83**).

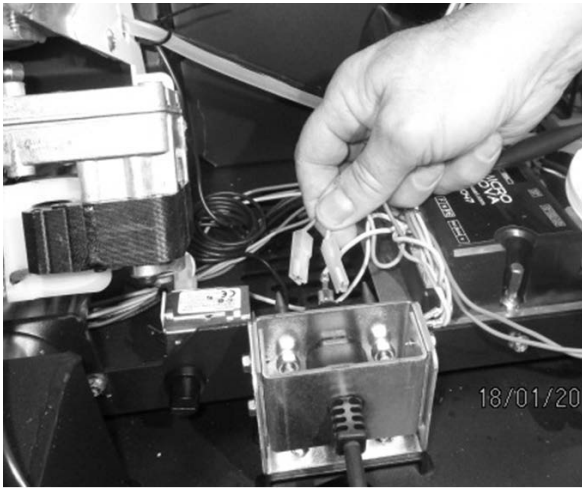
## 6 WI-FI KIT INSTALLATION

To install the WI-FI Kit, make the power supply cable with plug and faston (see **Fig. 84**)

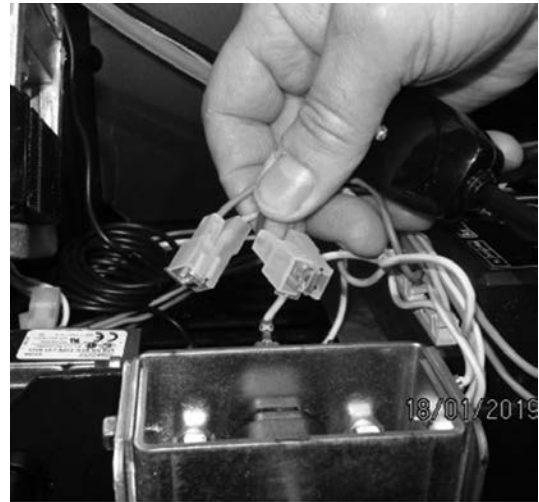


**Fig. 84 - Plug + Faston**

Disconnect the power supply faston (blue - brown) connected directly to the socket and connect them on the double faston of the power supply cable. Reconnect everything to the main socket. (see **Fig. 85 Fig. 86**)



**Fig. 85 - Faston disconnection (blue - brown)**



**Fig. 86 - Double faston connection**

Fix the WI-FI module on the bottom of the tank with the power supply cable and the serial cable connected and lock the wi-fi module feeder on the strut with cable ties as shown. (see **Fig. 87**)



**Fig. 87 - WI-FI module fixing**

## 7 SPECIAL MAINTENANCE

### 7.1 INTRODUCTION

For a long working life of the stove, have a periodic cleaning of the stove as described in the following paragraphs.

- Fume outlet pipes (fume conduit + chimney flue + chimney pot) must always be cleaned, scrubbed and checked by an authorized technician in compliance with local regulations, with the instructions of the manufacturer and those of your insurance company.
- It is also necessary to have the combustion chamber, motors and fans cleaned and to have the gaskets and the electrical elements checked at least once a year.



*All these operations must be planned in time with your Authorized Technical Assistance Service.*

- After a long ineffective time, before turning on the stove check if there are obstructions in the fume exhaust.
- If the stove had been using continuously and intensely, the whole system (chimney included), must be cleaned and checked more frequently.
- In case of replacement of damaged pieces please ask for the original spare part at the Authorized Retailer.

## 7.2 FEED SCREW MAINTENANCE

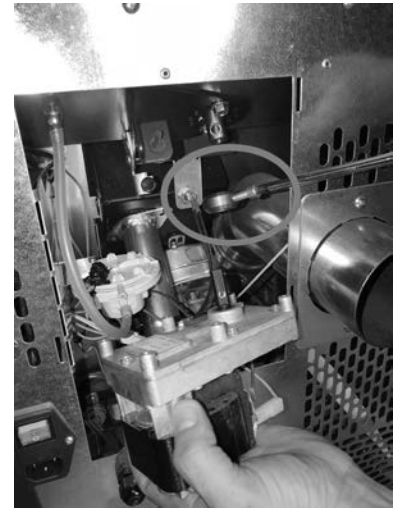
Proceed as follows for the feed screw maintenance:



*Fig. 88 - Screw removal*



*Fig. 89 - Coque removal*



*Fig. 90 - Gear motor removal*

- Enter the tank and loosen the 4 screws of the feed screw coque (see **Fig. 88**).
- Remove the coque (see **Fig. 89**).
- Remove the gear motor by loosening the locking screw (see **Fig. 90**).



*Fig. 91 - Spiral removal*



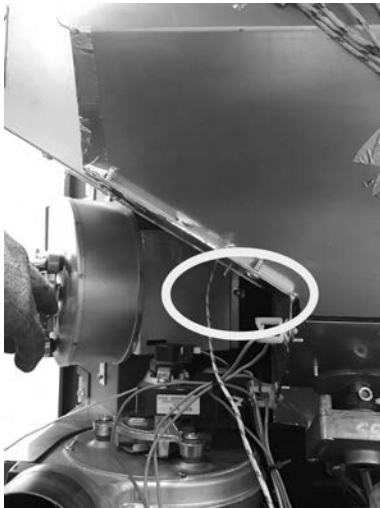
*Fig. 92 - Bearing removal*

- Remove the spiral (see **Fig. 91**).
- If worn, remove the bearing (see **Fig. 92**) and replace it.
- To reassemble, proceed in reverse order.

## 7.3 FLUE GAS EXTRACTOR CLEANING

Every year, clean the flue gas extractor to remove ash or dust causing unbalance of the blades and greater noise.

- Remove the insert and loosen the screw behind the right fan (see **Fig. 93**).
- Remove the front screws of the fan (see **Fig. 94** and **Fig. 95**).



**Fig. 93 - Loosen the screw**



**Fig. 94 - Remove screw 1**

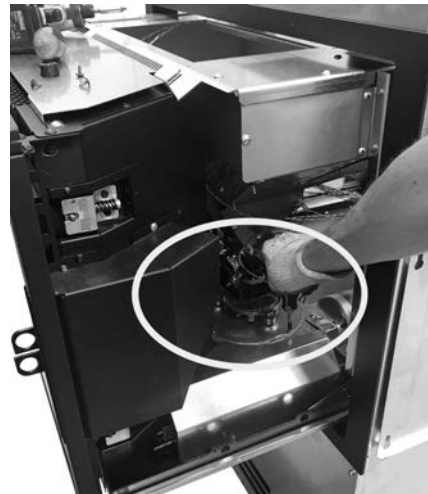


**Fig. 95 - Remove screw 2**

- Disconnect the wiring and remove the fan (see **Fig. 96**).
- Remove the flue gas extractor screws (see **Fig. 97**) and proceed with cleaning.



**Fig. 96 - Remove the fan**



**Fig. 97 - Remove the screws**

- Clean with a brush and vacuum the soot inside (see **Fig. 98** and **Fig. 99**).
- Once thoroughly cleaned, put everything back together.



**Fig. 98 - Cleaning 1**



**Fig. 99 - Cleaning 2**

## 7.4 FUME PIPES ANNUAL CLEANING



Clean once a week from soot with brushes.



The cleaning operation must be executed by a specialized stove-repairer who will provide for the cleaning of fume pipe, chimney flue and chimney pot. He will also check their efficiency and will release a written declaration of the safety of the appliance. This operation must be executed at least once a year.

## 7.5 GASKET REPLACEMENT

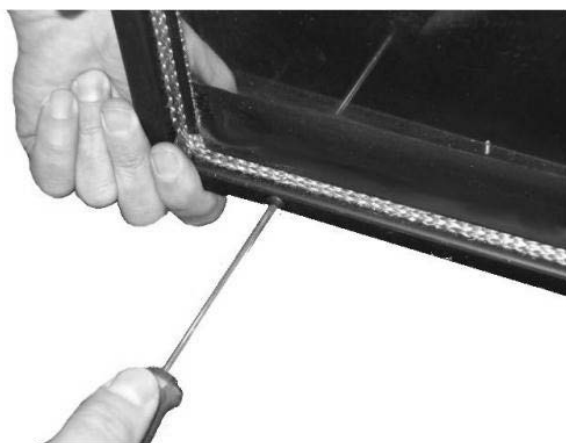
In case of deterioration of fire door, hopper or fume chamber gaskets, it is necessary to replace them by an authorized technician in order to guarantee the good running of the stove.



*Use exclusively original spare parts.*

## 7.6 GLASS REPLACEMENT

In case of break it is essential to replace it before using the stove.  
For glass replacement please proceed as follows:



*Fig. 100 - Screw removal*



*Fig. 101 - Door profiles removal*

- Remove the screws from glassweight profiles (see **Fig. 100**).
- Remove upper and lower profiles (see **Fig. 101**).
- Take out the damaged glass and replace it only with an original spare part. Please check that the gasket is not damaged and if necessary, have it replaced.
- Reassemble the profiles and screws.

## 8 IN CASE OF ANOMALY












### 8.1 PROBLEM SOLVING























*Before of every Authorized Technician intervention, the same Technician has the duty to check if the parameters of the mother board correspond to those of the table you own.*



*In case of doubts regarding the use of the stove, please contact ALWAYS the Authorized Technician on order to avoi irreparable damages!*

PROBLEM	CAUSE	SOLUTION	INTERVENTION
The control display does not switch on	The stove is without power supply	Check if the plug is connected.	
	Burned protection fuse in the electric socket	Replace the protection fuses in the electric socket (3.15A-250V).	
	Faulty control display	Replace the control display.	
	Faulty flat cable	Replace the flat cable.	
	Faulty electronic board	Replace the mother board.	
Pellets do not reach the combustion chamber	Empty hopper	Full the hopper.	
	Open fire door or open pellet door	Close fire door and pellet door and check that there are no pellet grains at the gasket level.	
	Clogged stove	Fume chamber cleaning	
	Auger blocked by a foreign object (for example nails)	Clean the auger.	
	The auger geared motor is out of order	Replace the geared motor.	
	Check if on the display there is an "ACTIVE ALARM"	Have the stove checked.	

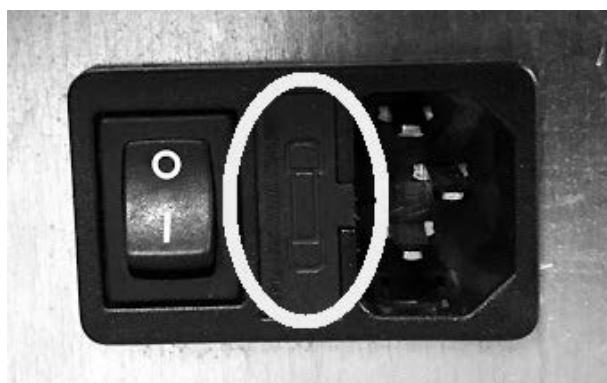
PROBLEM	CAUSE	SOLUTION	INTERVENTION
The fire extinguish and the stove stops	Empty hopper	Full the hopper.	
	Auger blocked by a foreign object (for example nails)	Clean the auger.	
	Bad quality pellets	Try other types of pellets.	
	Pellet drop value too low "phase 1"	Adjust the pellet loading.	
	Check if on the display there is an "ACTIVE ALARM"	Have the stove checked.	
Flames are weak and orange coloured, pellets do not burn properly and the glass blackens	Not sufficient combustion air	Check as following: probable obstructions of the combustible air inlet from the back or from the bottom of the stove; burning pot obstructed holes with too ash remains. Have the fan blades and auger cleaned.	
	Obstructed exhaust	The exhaust chimney is partially or totally obstructed. Contact an expert stove-repairer who checks the stove from the exhaust up to the chimney pot. Provide immediately for stove cleaning.	
	Obstructed stove	Provide immediately at the inner cleaning of the stove.	
	The fume fan is out of order	The pellets can burn also thanks to chimney flue depression without the aid of the fume fan. Have the fume fan immediately replaced. It can be noxious to health to let the stove running without fume fan.	
The exchanger fan continues to turn even though the stove has just cooled	Faulty fume temperature probe	Replace the fume probe.	
	Faulty mother board	Replace the mother board.	
Ash remains along the stove	Faulty or out of order door gaskets	Replace the gaskets.	
	Not sealed fume pipes	Contact an expert stove-repairer who will immediately provide for sealing the junctions with high-temperature silicone and/or for replacing pipes with those in compliance to current regulations. A not sealed fume channelisation can be noxious to health.	

PROBLEM	CAUSE	SOLUTION	INTERVENTION
The stove is at its highest power but does not heat up.	Ambient temperature reached.	The stove is at its minimum value. Increase the desired ambient temperature.	
Stove running and display showing "Smoke Overtemperature"	Reached fume outlet limit temperature	The stove runs at minimum. NO PROBLEM!	
The stove's smoke duct produces condensation	Low smoke temperature	Check that the flue is not clogged.	
		Increase stove power to minimum (pellet drop and fan revs).	
		Install condensation collection cup.	
Stove running and display showing "SERVICE"	Routine maintenance alert (it does not block the system)	When this flashing message appears upon start-up, it means that the preset operating hours have elapsed before maintenance. Contact the service centre.	
"Pellet reserve enabling" activates with the tank full	Failure to reach the threshold temperature, large or poor quality pellet, clogged fume passage	Increase pellet with "Pellet Recipe" or clean the combustion chamber	

## 9 TECHNICAL DATAS

### 9.1 FUSE REPLACEMENT

For fuse replacement in the electric socket which stands on the back of the stove, extract the fuses to change with the aid of a screwdriver for opening the shutter (see **Fig. 102**).



**Fig. 102 - Shutter with fuses to remove**

## 9.2 FEATURES

DESCRIPTION	ZEFIRO <sup>3</sup> - 9 kW	ZEN AIRTIGHT - 9 kW
WIDTH	69,7 cm	69,7 cm
DEPTH	55 cm	55 cm
HEIGHT	49 cm	49 cm
WEIGHT	105 kg	105 kg
INTRODUCED THERMAL POWER (Min/Max)	2,83 - 10,46 kW	2,83 - 10,46 kW
NOMINAL THERMAL POWER (Min/Max)	2,7 - 9,26 kW	2,7 - 9,26 kW
EFFICIENCY (Min/Max)	94,2 - 88,5 %	94,2 - 88,5 %
FLUE GAS TEMPERATURE (Min/Max)	79 - 197°C	79 - 197°C
MAXIMUM FLUE GAS FLOW RATE (Min/Max)	2,6 - 5,7 g/s	2,6 - 5,7 g/s
CO EMISSIONS (13% O <sub>2</sub> ) (Min/Max)	0,024 - 0,012 %	0,024 - 0,012 %
OGC EMISSIONS (13% O <sub>2</sub> ) (Min/Max)	3,3 - 2,6 mg/Nm <sup>3</sup>	3,3 - 2,6 mg/Nm <sup>3</sup>
NOX EMISSIONS (13% O <sub>2</sub> ) (Min/Max)	108 - 127 mg/Nm <sup>3</sup>	108 - 127 mg/Nm <sup>3</sup>
Average CO CONTENT at 13% O <sub>2</sub> (Min/Max)	294 - 148 mg/Nm <sup>3</sup>	294 - 148 mg/Nm <sup>3</sup>
Average DUST CONTENT at 13% O <sub>2</sub> (Min/Max)	19,2 - 18,9 mg/Nm <sup>3</sup>	19,2 - 18,9 mg/Nm <sup>3</sup>
FLUE NEGATIVE PRESSURE (Max)	11,9 Pa	11,9 Pa
ON SHARED FLUE	NO	NO
FLUE GAS EXHAUST DIAMETER	Ø80 mm	Ø80 mm
FUEL	Pellet Ø6-7 mm	Pellet Ø6-7 mm
PELLET HEATING CAPACITY	5 kWh/kg	5 kWh/kg
PELLET HUMIDITY	≤ 10%	≤ 10%
HEATABLE VOLUME 18/20°C Coeff. 0.045 kW (Min/Max)	62,4 - 222 m <sup>3</sup>	62,4 - 222 m <sup>3</sup>
HOURLY CONSUMPTION (Min/Max)	0,59 - 2,17 kg/h	0,59 - 2,17 kg/h
HOPPER CAPACITY	15 kg	15 kg
RANGE (Min/Max)	25 - 6,9 h	25 - 6,9 h
POWER SUPPLY	230 V - 50 Hz	230 V - 50 Hz
ABSORBED POWER (Max)	346 W	346 W
STARTER RESISTANCE ABSORBED POWER	300 W	300 W
MINIMUM EXTERNAL AIR VENT (final cross-section)	80 cm <sup>2</sup>	80 cm <sup>2</sup>
SEALED CHAMBER STOVE	YES	YES
EXTERNAL AIR VENT FOR SEALED CHAMBER	60 mm	60 mm
DISTANCE FROM COMBUSTIBLE MATERIAL (back/side/bottom)	200 / 200 / 0 mm	200 / 200 / 0 mm
DISTANCE FROM COMBUSTIBLE MATERIAL (ceiling/front)	750 / 1000 mm	750 / 1000 mm



890180978

*Rev. 00-2020*

**CADEL srl**  
**31025 S. Lucia di Piave - TV**  
**Via Foresto sud, 7 - Italy**  
**Tel. +39.0438.738669**  
**Fax +39.0438.73343**

**[www.cadelsrl.com](http://www.cadelsrl.com)**  
**[www.free-point.it](http://www.free-point.it)**